

DATOS TÉCNICOS DATASHEET

MARCA / BRAND : ELECTRO DH
CÓDIGO / CODE : 81.764/5/BLANCA

DESCRIPCIÓN: ESTACA LED 5W PARA JARDÍN
DESCRIPTION: LED GARDEN LIGHT 5W

ESPECIFICACIONES TÉCNICAS TECHNICAL SPECIFICATIONS

Voltaje de entrada/ Input voltage:	85-265V
Vatios nominales/ Nominal watts:	5W
Temperatura de color/ Color temperature:	4000K
Flujo luminoso/ Luminous flux:	80 lm x W
Distancia efectiva/ Effective distance:	5-8 m
Ángulo de haz/ Beam angle:	45° - 60°
Temperatura de trabajo/ Operating temperature:	-25°C +45°C
Tipo de led/ Led chips:	TW COB
Grado de protección/ Degree of protection:	IP65
Material del cuerpo/ Body material:	Fundición a presión/ pintura mate Die-casting/ pintura mate

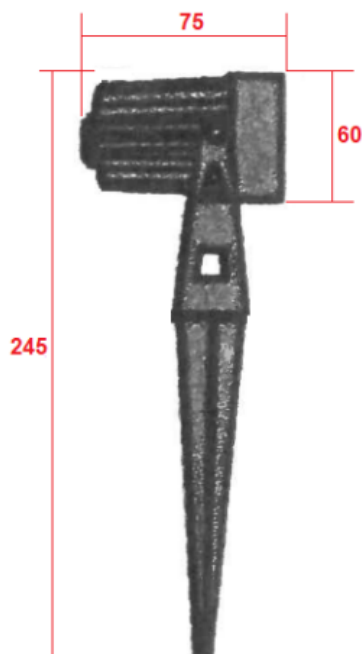

ELECTRO DH s.a.

Fortuna 29
08902 Hospitalet de LL (BCN)

