



DATOS TÉCNICOS DATASHEET

MARCA : ELECTRO DH

BRAND: ELECTRO DH

CÓDIGO: 71.200

CODE: 71.200

DESCRIPCIÓN: VENTILADOR A FRICCIÓN 24Vcc

DESCRIPTION: FRICTION FAN 24Vcc



ESPECIFICACIONES TÉCNICAS

TECHNICAL SPECIFICATIONS

VOLTAJE:	24Vcc
VOLTAGE:	24Vcc
COJINETES:	Fricción
BEARINGS:	Friction
CORRIENTE:	180 mA
CURRENT:	180 mA
POTENCIA:	4.32 W
POWER:	4.32 W
VELOCIDAD:	3000 rpm
SPEED:	3000 rpm
CAUDAL:	100 m ³ /min.
FLOW:	100 m ³ /min.
RUIDO:	46.6 db
NOISE:	46.6 db
PESO:	350 grs.
WEIGHT:	350 grs.
CHASIS:	Plástico
CHASSIS:	Plastic

ELECTRO DH s.a.

Fortuna 29
08902 Hospitalet de LL (BCN)



DATOS TÉCNICOS DATASHEET

Medidas:

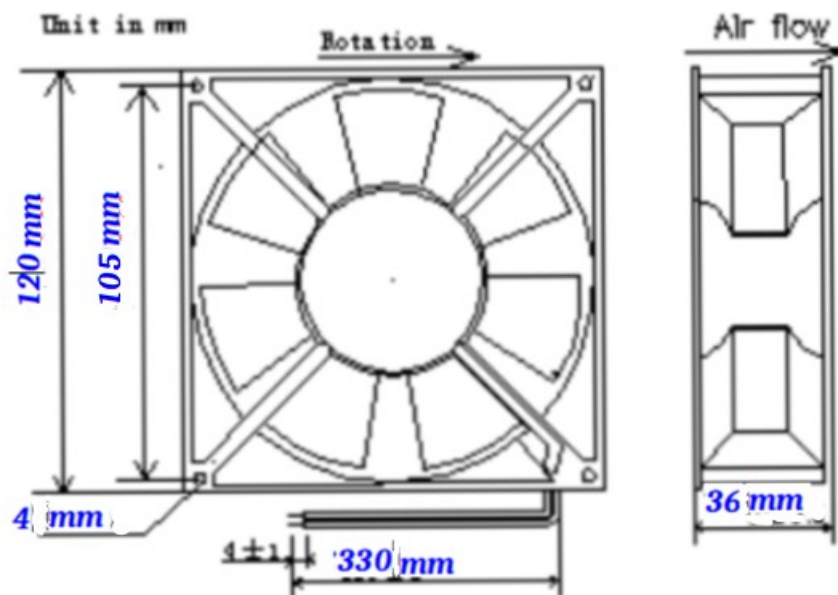

ELECTRO DH s.a.

Fortuna 29
08902 Hospitalet de LL (BCN)