



DATOS TÉCNICOS DATASHEET

MARCA : ELECTRO DH
BRAND: ELECTRO DH
CÓDIGO: 71.190
CODE: 71.190
DESCRIPCIÓN: VENTILADOR A FRICCIÓN 12Vcc
DESCRIPTION: FRICTION FAN 12Vcc



ESPECIFICACIONES TÉCNICAS TECHNICAL SPECIFICATIONS

VOLTAJE:	12Vcc
VOLTAGE:	12Vcc
COJINETES:	Fricción
BEARINGS:	Friction
CORRIENTE:	320 mA
CURRENT:	320 mA
POTENCIA:	3.84 W
POWER:	3.84 W
VELOCIDAD:	2800 rpm
SPEED:	2800 rpm
CAUDAL:	100 m ³ /min.
FLOW:	100 m ³ /min.
RUIDO:	46.6 db
NOISE:	46.6 db
PESO:	339 grs.
WEIGHT:	339 grs.
CHASIS:	Plástico
CHASSIS:	Plastic

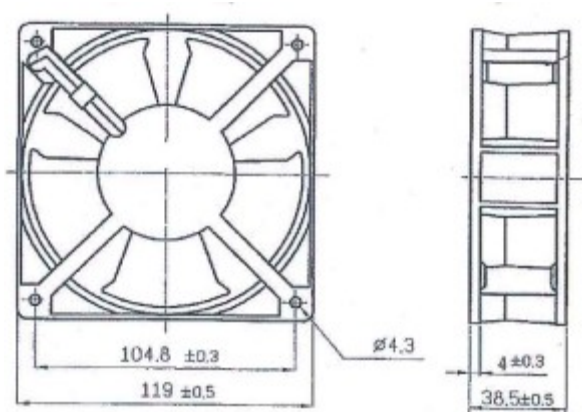

ELECTRO DH s.a.

Fortuna 29
08902 Hospitalet de LL (BCN)