

DATOS TÉCNICOS DATASHEET

Pag. 1/2

MARCA : ELECTRO DH

BRAND: ELECTRO DH

CÓDIGO: 71.180

CODE: 71.180

DESCRIPCIÓN: VENTILADOR A FRICCIÓN 24Vcc

DESCRIPTION: FRICTION FAN 24 Vcc



ESPECIFICACIONES TÉCNICAS

TECHNICAL SPECIFICATIONS

VOLTAJE:	24VCC
VOLTAGE:	24VDC
COJINETES:	Fricción
BEARINGS:	Friction
CORRIENTE:	280 mA
CURRENT:	280 mA
POTENCIA:	6,72 W
POWER:	6,72 W
VELOCIDAD:	2500 rpm
SPEED:	2500 rpm
CAUDAL:	100 m ³ /min.
FLOW:	100 m ³ /min.
PRESION:	6.0 mmH2O
PRESSURE:	6.0 mmH2O
RUIDO:	43.3 dBA
NOISE:	43.3 Dba
RESISTENCIA DE AISLAMIENTO:	10MΩ at 500 VDC entre cable y marco
ISOLATION RESISTANCE:	10MΩ at 500 VDC between lead and frame
RIGIDEZ DIELECTRICA:	500VCA/min, corriente < 5mA
DIELECTRIC STRENGHT:	500VAC/min, current < 5mA
TEMPERATURA DE TRABAJO:	-20°C ~ 80°C
WORKING TEMPERATURE:	-20°C ~ 80°C
VOLTAJE DE FUNCIONAMIENTO:	24VCC ± 15%
WORKING VOLTAGE:	24VDC ± 15%
PESO:	160 grs.
WEIGHT:	160 grs.
CHASIS:	Plástico
CHASSIS:	Plastic

ELECTRO DH s.a.

Fortuna 29
08902 Hospitalet de LL (BCN)

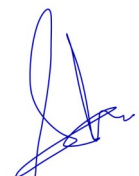

MEDIDAS:
MEASURES:

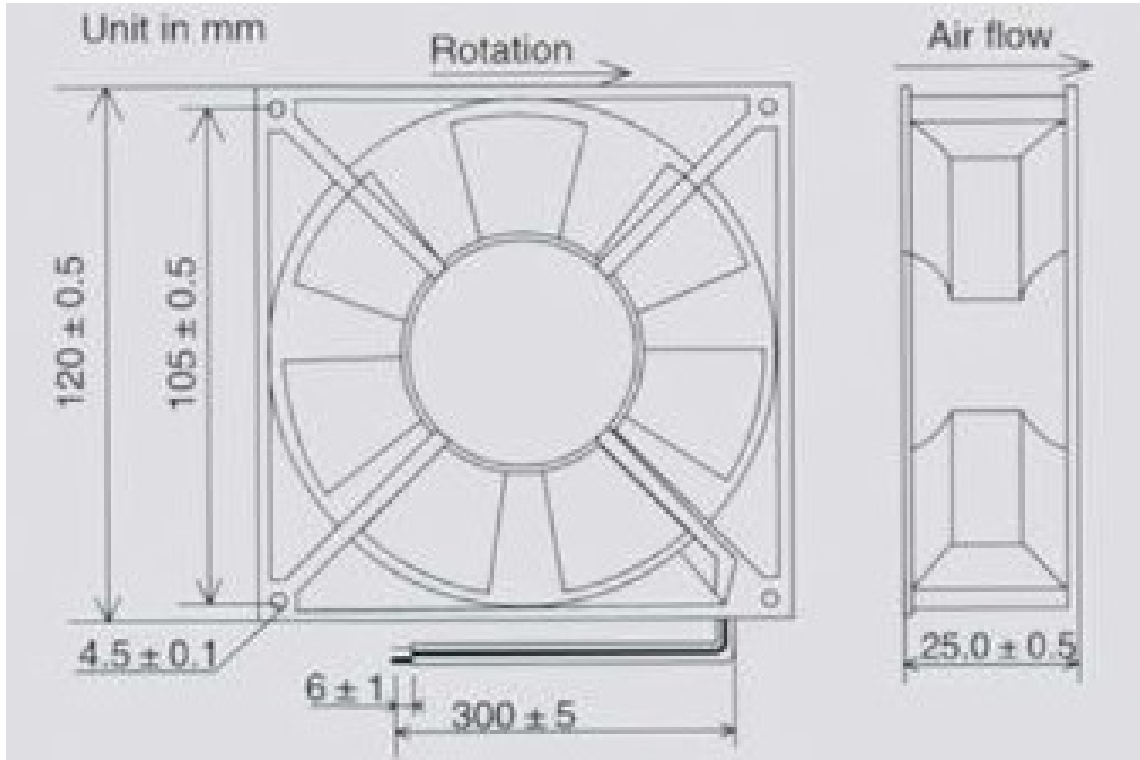

ELECTRO DH s.a.
Fortuna 29
08902 Hospitalet de LL (BCN)