

DATOS TÉCNICOS DATASHEET

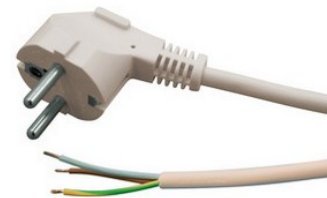

MARCA : ELECTRO DH

BRAND: ELECTRO DH

CÓDIGO: 36.752/150/B – 36.752/150/N – 36.752/180/B – 36.752/180/N – 36.752/300/B

CODE: 36.752/150/B – 36.752/150/N – 36.752/180/B – 36.752/180/N – 36.752/300/B

DESCRIPCIÓN: CONEXIÓN SCHUKO + NF

DESCRIPTION: SCHUKO + NF CONNECTION

ESPECIFICACIONES TÉCNICAS

TECHNICAL SPECIFICATIONS

Tensión nominal:	250 VCA
Rated voltage:	250 VCA
Intensidad nominal:	16 A
Nominal intensity:	16 A
Potencia máxima:	3500 W
Maximum power:	3500 W
Cable:	3G x Ø 1.5 mm² (48 cables de 0,20mm)
Cable:	3G x Ø 1.5 mm² (48 cables of 0,20mm)
Tipo de cable:	H05VV-F policloruro de vinilo (PVC)
Type of cable:	H05VV-F polyvinylchloride (PVC)
Grado de protección al agua:	IP20
Degree of protection to water:	IP20
Resistencia de aislamiento:	>100MΩ
Insulation resistance:	>100MΩ
Rigidez dieléctrica:	2500V (no hay rotura)
Dielectric strength:	2500V (there is no break)
Protección para niños:	Si
Protection for children:	Yes

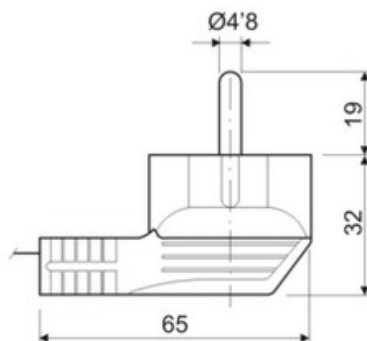

ELECTRO DH s.a.

Fortuna 29
08902 Hospitalet de LL (BCN)

