

DATOS TÉCNICOS DATASHEET

MARCA : ELECTRO DH
BRAND: ELECTRO DH
CÓDIGO: 36.370
CODE: 36.370
DESCRIPCIÓN: BASE DE ENCHUFE EMPOTRABLE
DESCRIPTION: RECESSED SOCKET



ESPECIFICACIONES TÉCNICAS TECHNICAL SPECIFICATIONS

Voltaje nominal:	250 V
Rated voltage:	250 V
Corriente nominal:	16 A
Rated current:	16 A
Protección IP:	54
IP-Class:	54
Máximo vataje:	3680 W
Maximum vatage:	3680 W
Tapa:	De cierre automático
Top:	Automatic closing
Terminales:	De tipo tornillo para conductores flexibles de 1,0-1,5mm ²
Terminals:	Of screw type for flexible conductors of 1,0-1,5mm ²

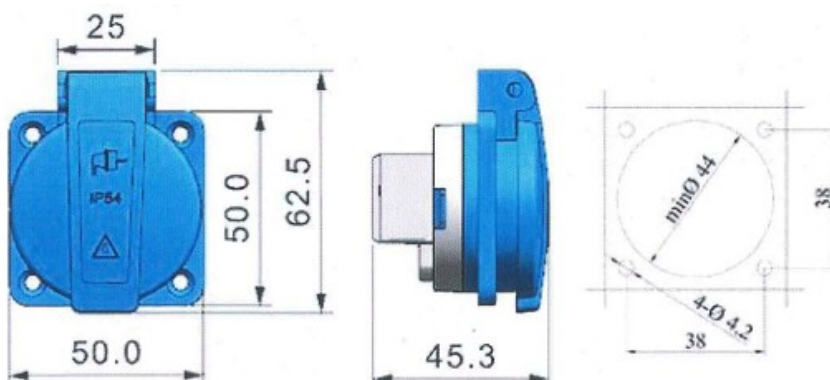

ELECTRO DH s.a.

Fortuna 29
08902 Hospitalet de LL (BCN)

