

### DATOS TÉCNICOS

#### DATASHEET

**MARCA / BRAND : ELECTRO DH**  
**CÓDIGO / CODE : 36.101**

**DESCRIPCIÓN: BASE 3 TOMAS CON CABLE 1,5M**  
**DESCRIPTION: 3 OUTLET BASE WITH 1.5M CABLE**



### ESPECIFICACIONES TÉCNICAS

#### TECHNICAL SPECIFICATIONS

<b>Tensión de entrada/ Input voltage:</b>	<b>250V</b>
<b>Intensidad máxima/ Maximum intensity:</b>	<b>16A</b>
<b>Potencia máxima/ Maximum power:</b>	<b>3680W</b>
<b>Cubierta/ Cover:</b>	<b>Policarbonato/ Polycarbonate PC110</b>
<b>Base/ Base:</b>	<b>Policarbonato/ Polycarbonate PC110</b>
<b>Cubierta pequeña/ Small cover:</b>	<b>Policarbonato/ Polycarbonate PC110</b>
<b>Tapa del tornillo/ Screw cover:</b>	<b>Policarbonato/ Polycarbonate PC110</b>
<b>Disco de tensión/ Tension disc:</b>	<b>Poliamida 66/ Polyamide 66 PA66</b>
<b>Funda/ Sheath:</b>	<b>Policloruro de polivinilo Polyvinyl chloride PVC001</b>
<b>Obturador/ Shutter:</b>	<b>Poliamida 66 + 30% fibra de vidrio Polyamide 66 + 30% fiberglass PA66+G30</b>
<b>Contacto/ Contact:</b>	<b>0.4mm H62 limpieza ácida/ acid cleaning</b>
<b>Contacto de tierra/ Earth contact:</b>	<b>0.8QSn6.5-0.1 Niquelado/ Nickel plated</b>
<b>Muelle del obturador/ Spring for shutter:</b>	<b>65Mn</b>
<b>Tornillo/ Screw:</b>	<b>A3 Niquelado/ Nickel plated</b>

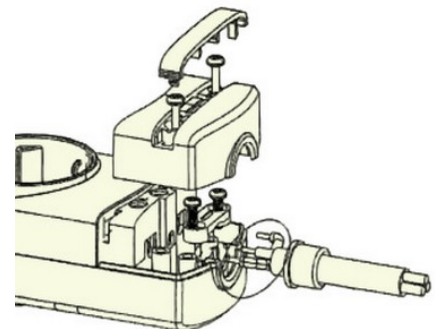
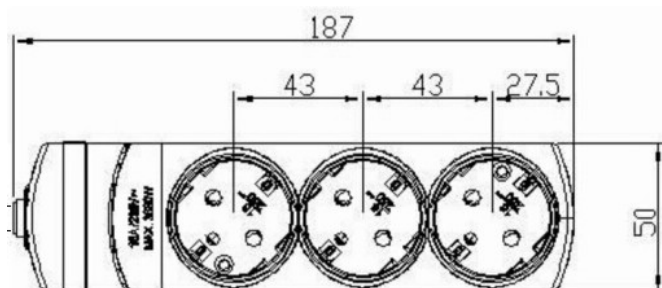
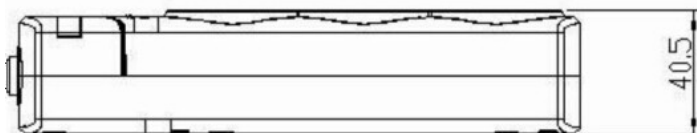

**ELECTRO DH s.a.**

Fortuna 29  
08902 Hospitalet de LL (BCN)

