

DATOS TÉCNICOS DATASHEET

MARCA / BRAND : ELECTRO DH
CÓDIGO / CODE : 17.030

DESCRIPCIÓN: CONMUTADOR DESLIZANTE
DESCRIPTION: SLIDE SWITCH

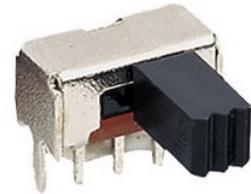

ESPECIFICACIONES TÉCNICAS TECHNICAL SPECIFICATIONS

Circuitos/Circuits:	1
Posiciones/Positions:	2
Corriente nominal/Rating:	DC 30V 0.3A
Resistencia de contacto/Contact resistance:	30mΩ max.
Resistencia de aislamiento/Insulation resistance:	500MΩ a/at 500V DC
Temperatura de trabajo/Temperature range:	-10°C ~ +60°C
Fuerza operativa/Operating force:	250gf ± 100gf
Vida eléctrica/Life:	10.000 ciclos/cycles
Terminal/Terminal:	Latón plateado/silver brass
Botón:	Termoplástico semicristalino VG 2-10
Knob:	POM VG 2-10
Base de los terminales/Terminal base:	Resina fenólica/Phenol resin

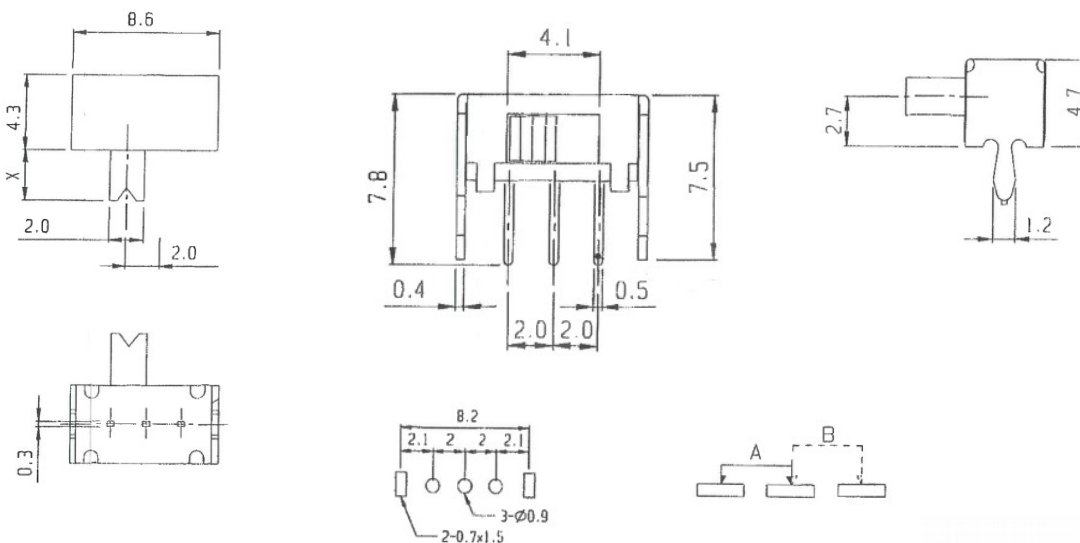

ELECTRO DH s.a.
Fortuna 29
08902 Hospitalet de LL (BCN)

