

DATOS TÉCNICOS

DATASHEET

MARCA / BRAND : ELECTRO DH
CÓDIGO / CODE : 12.144/T8/T

DESCRIPCIÓN: PORTALÁMPARAS G13
DESCRIPTION: G13 LAMP HOLDERS

ESPECIFICACIONES TÉCNICAS

TECHNICAL SPECIFICATIONS

Corriente nominal / Rated current:	2A
Voltaje nominal / Rated voltage:	250V
Temperatura nominal/Rated temperature:	T110°C
Cable aplicable/Applicable wire:	0.5 – 1 mm²
Material del cuerpo/Body material:	Polycarbonato/Polycarbonate (PC)
Terminales/Terminals:	Bronce fosforado/Phosphor bronze
Espesor de panel/Panel thickness:	1 a/to 1,3mm
Protección IP/IP protection:	IP54
Fuerza de extracción/Extraction force:	>50N

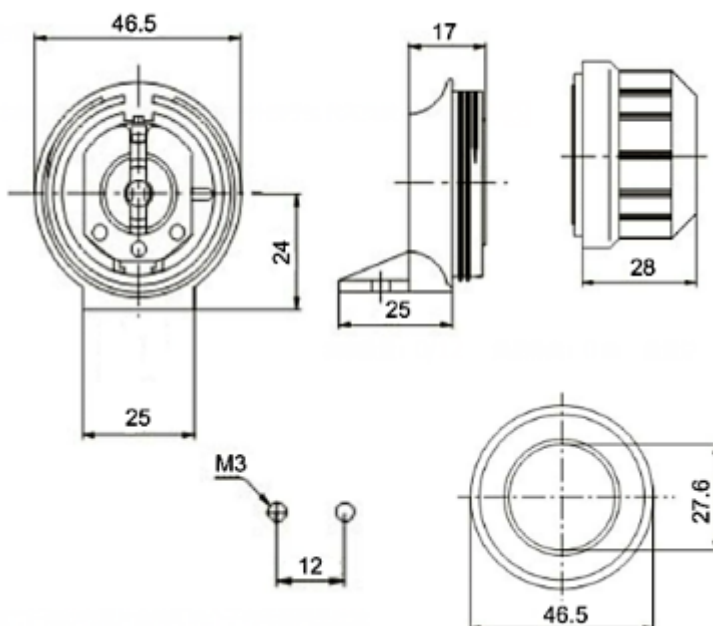

ELECTRO DH s.a.

Fortuna 29
08902 Hospitalet de LL (BCN)

