

### DATOS TÉCNICOS

#### DATASHEET

**MARCA :** ELECTRO DH

**BRAND:** ELECTRO DH

**CÓDIGO:** 12.144/T8

**CODE:** 12.144/T8

**DESCRIPCIÓN:** PORTALÁMPARAS PARA FLUORESCENTE

**DESCRIPTION:** FLUORESCENT LAMP HOLDER



### ESPECIFICACIONES TÉCNICAS

#### TECHNICAL SPECIFICATIONS

**Material principal:**

Policarbonato (PC)

**The main material:**

Polycarbonate (PC)

**Protección al agua:**

IP54

**Waterproof level:**

IP54

**Corriente nominal:**

2 A

**Rated current:**

2 A

**Voltaje nominal:**

250 V

**Rated voltage:**

250 V

**Sección de cable:**

0.5 – 1 mm<sup>2</sup>

**Cable section:**

0.5 – 1 mm<sup>2</sup>

**Firmeza:**

No desmontable

**Firmness:**

Not detachable

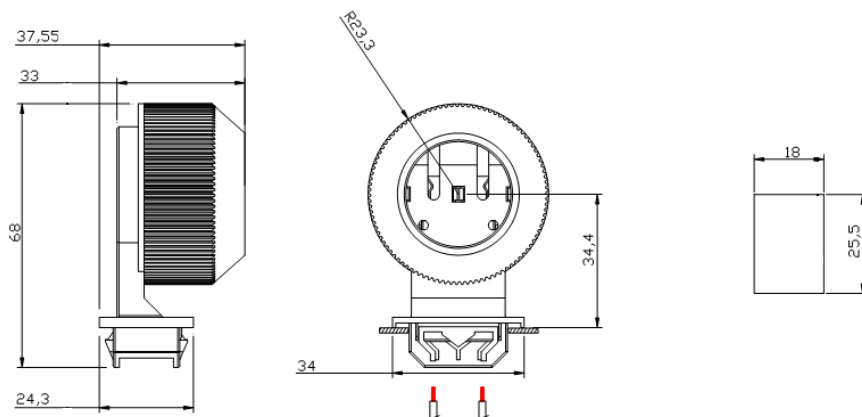

**ELECTRO DH s.a.**

Fortuna 29  
08902 Hospitalet de LL (BCN)

