



DATOS TÉCNICOS DATASHEET

MARCA : ELECTRO DH

BRAND: ELECTRO DH

CÓDIGO: 11.551

CODE: 11.551

DESCRIPCIÓN: REGULADOR DE LUZ PARA PIE

DESCRIPTION: LIGHT REGULATOR FOR FOOT



ESPECIFICACIONES TÉCNICAS

TECHNICAL SPECIFICATIONS

| | |
|-----------------------------------|------------------------------|
| Voltaje: | 220-240 Vac 50/60 Hz |
| Voltage: | 220-240 Vac 50/60 Hz |
| Carga nominal: | 300 W max. |
| Rated loading: | 300 W max. |
| Temperatura ambiente: | 45°C |
| Room temperature: | 45°C |
| Vida regulable: | 10000 ciclos min. |
| Dimmable life: | 10000 cycles min. |
| Forma regulable: | Deslizable con el pie |
| Dimmable way: | Food slide |
| Rigidez dieléctrica: | 4K Vac max. |
| Dielectric strength: | 4K Vac max. |
| Medidas: | L103xW60xH30 |
| Size: | L103xW60xH30 |
| Material: | Policarbonato (PC) |
| Material: | Polycarbonate (PC) |
| Protección contra el calor | |
| Over heat protect | |
| Prevención de fuego | |
| Fire prevention | |

ELECTRO DH s.a.
Fortuna 29
08902 Hospitalet de LL (BCN)



DATOS TÉCNICOS DATASHEET

MARCA : ELECTRO DH

BRAND: ELECTRO DH

CÓDIGO: 11.551

CODE: 11.551

DESCRIPCIÓN: REGULADOR DE LUZ PARA PIE

DESCRIPTION: LIGHT REGULATOR FOR FOOT

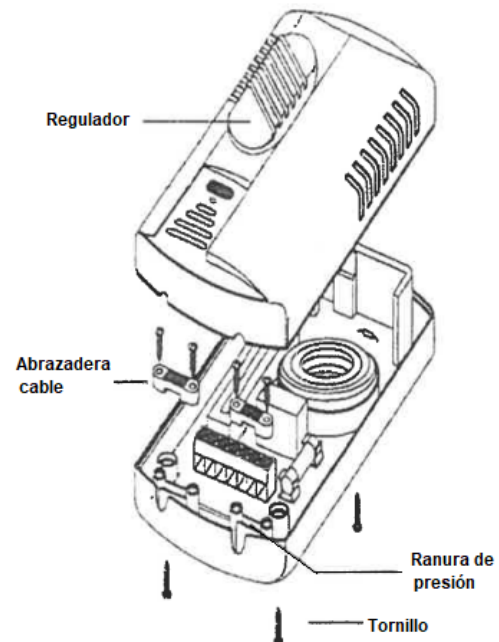
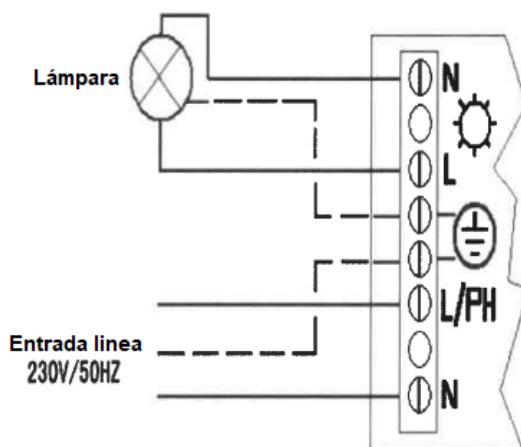
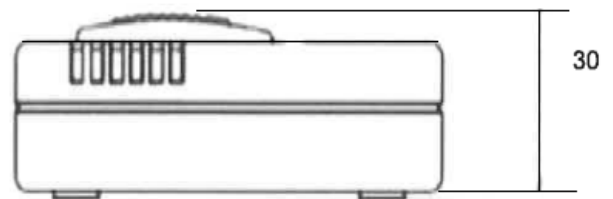
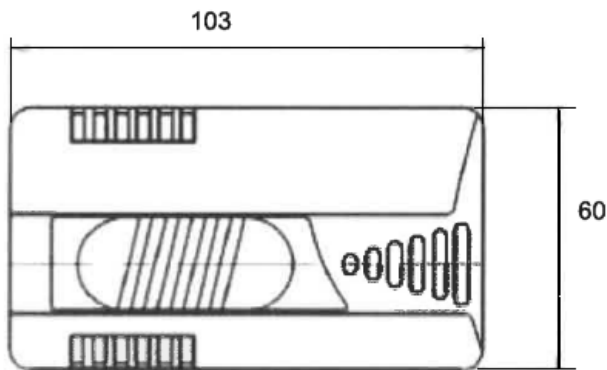

ELECTRO DH s.a.

Fortuna 29
08902 Hospitalet de LL (BCN)