

### DATOS TÉCNICOS DATASHEET

**MARCA :** ELECTRO DH  
**BRAND:** ELECTRO DH  
**CÓDIGO:** 11.478.IL  
**CODE:** 11.478.IL  
**DESCRIPCIÓN:** INTERRUPTOR LUMINOSO  
**DESCRIPTION:** LIGHT SWITCH



### ESPECIFICACIONES TÉCNICAS TECHNICAL SPECIFICATIONS

<b>Clasificación:</b>	<b>ULC-UL: 10A 125 VAC</b>
	<b>ENEC SEMKO: 6(2)A 250 VAC T125551E4</b>
<b>Rating:</b>	<b>ULC-UL: 10A 125 VAC</b>
	<b>ENEC SEMKO: 6(2)A 250 VAC T125551E4</b>
<b>Circuito:</b>	<b>ON-OFF Lamp SPST3P</b>
<b>Circuit:</b>	<b>ON-OFF Lamp SPST3P</b>
<b>Voltaje:</b>	<b>220 VAC</b>
<b>Voltage:</b>	<b>220 VAC</b>
<b>Resistencia de contacto:</b>	<b>30mOHMS max.</b>
<b>Contact resistance:</b>	<b>30mOHMS max.</b>
<b>Resistencia de aislamiento:</b>	<b>DC 500V 100mOHMS min.</b>
<b>Insulation resistance:</b>	<b>DC 500V 100mOHMS min.</b>
<b>Tensión soportada:</b>	<b>AC 1500V 1 minuto</b>
<b>Withstand voltage:</b>	<b>AC 1500V 1 minute</b>
<b>Vida eléctrica:</b>	<b>10000 ciclos a plena carga</b>
<b>Electrical life:</b>	<b>10000 cycles at full load</b>
<b>Fuerza de operación:</b>	<b>3 00~600gf</b>
<b>Operation force:</b>	<b>3 00~600gf</b>
<b>Rango de temperatura de operación:</b>	<b>-25°~+125° C</b>
<b>Operation temperature range:</b>	<b>-25°~+125° C</b>

**MATERIALES**

**MATERIALS**

**Alojamiento:**

**Housing:**

**Balancín:**

**Rocker:**

**Terminal:**

**Terminal:**

**Contactador:**

**Contactador:**

**Nylon 66UL94 V-2**

**Nylon 66UL94 V-2**

**PCUL94HB**

**PCUL94HB**

**Aleación de cobre-plateado**

**Copper Alloy Ag plated**

**AgSnO<sub>2</sub>In<sub>2</sub>O<sub>3</sub>(10) Cu**

**AgSnO<sub>2</sub>In<sub>2</sub>O<sub>3</sub>(10) Cu**

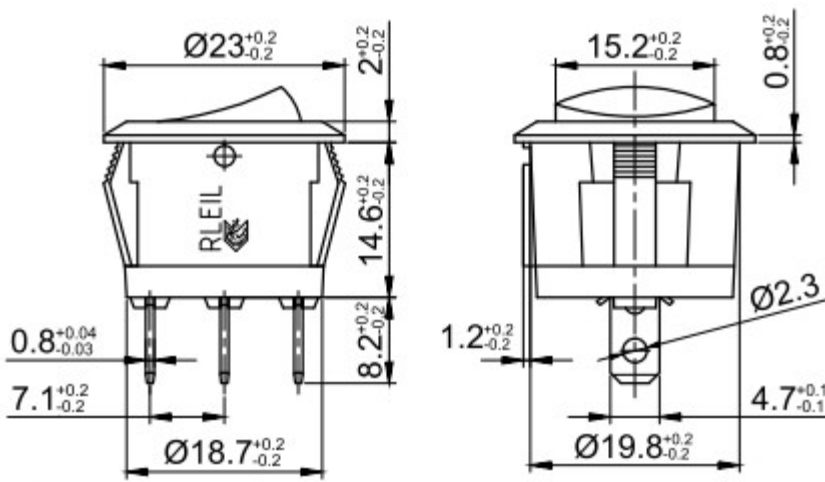

**DIAGRAMA DE CIRCUITO**

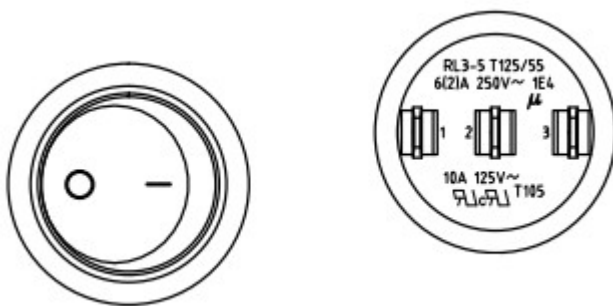
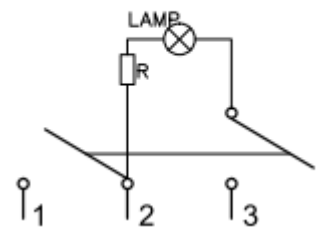

**PANEL DE AGUJEROS**

Espesor de panel	X
0.75-1.25	20.2
1.25-2.0	20.4
2.0-3.0	20.6

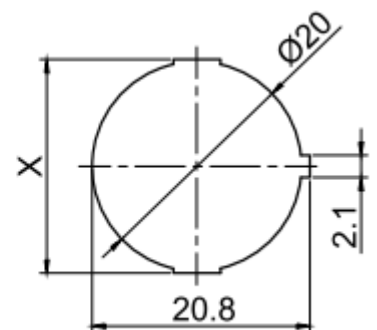

**ELECTRO DH s.a.**

Fortuna 29  
08902 Hospitalet de LL (BCN)