



## DATOS TÉCNICOS

### DATASHEET

**MARCA :** ELECTRO DH

**BRAND:** ELECTRO DH

**CÓDIGO:** 11.477.I/...

**CODE:** 11.477.I/...

**DESCRIPCIÓN:** Interruptor basculante empotrable

**DESCRIPTION:** Recessed rocker switch



## ESPECIFICACIONES TÉCNICAS

### TECHNICAL SPECIFICATIONS

|                                 |                        |
|---------------------------------|------------------------|
| <b>Tecla:</b>                   | Basculante             |
| <b>Key:</b>                     | Rocker                 |
| <b>Colores:</b>                 | Blanco o negro         |
| <b>Colors:</b>                  | White or black         |
| <b>Tensión nominal:</b>         | 250VAC-6A; 125VAC-10A. |
| <b>Rated voltage:</b>           | 250VAC-6A; 125VAC-10A. |
| <b>Resistencia de contacto:</b> | 35MΩ máx.              |
| <b>Contact resistance:</b>      | 35MΩ max.              |
| <b>Aislamiento a 500VDC:</b>    | 100MΩ mín.             |
| <b>500VDC insulation:</b>       | 100MΩ min.             |
| <b>Rigidez dieléctrica:</b>     | 1500VAC (1 minuto)     |
| <b>Dielectric strength:</b>     | 1500VAC (1 minute)     |
| <b>Temperatura de trabajo:</b>  | -25º a +85ºC.          |
| <b>Work temperature:</b>        | -25º to +85ºC.         |
| <b>Ciclos de vida on/off :</b>  | 10.000 ciclos          |
| <b>Life cycles on/off:</b>      | 10.000 cycles          |
| <b>Material:</b>                | Poliamida PA66         |
| <b>Material:</b>                | Polyamide PA66         |
| <b>Tornillos:</b>               | M3                     |
| <b>Screw:</b>                   | M3                     |
| <b>Intensidad máxima:</b>       | 6(2)A.                 |
| <b>Maximun intensity:</b>       | 6(2)A.                 |
| <b>Temperatura máxima:</b>      | 85ºC                   |
| <b>Maximun temperature:</b>     | 85ºC                   |

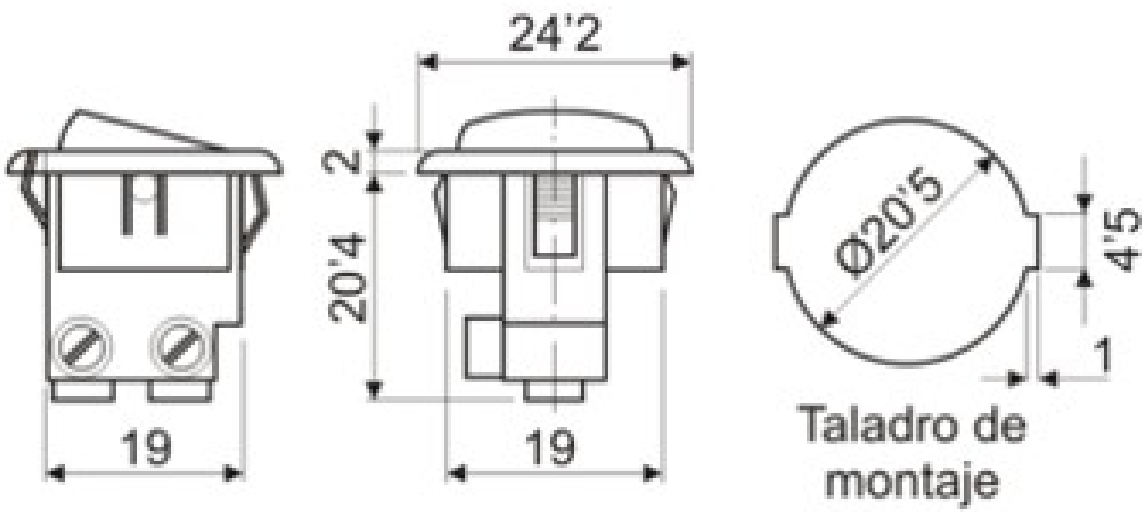

**ELECTRO DH S.A.**

Fortuna 29  
08902 Hospitalet de LL (BCN)