

### DATOS TÉCNICOS DATASHEET

**MARCA / BRAND :** ELECTRO DH  
**CÓDIGO / CODE :** 11.435.I/S

**DESCRIPCIÓN: INTERRUPTOR DE PALANCA**  
**DESCRIPTION: TOGGLE SWITCH**

#### ESPECIFICACIONES TÉCNICAS TECHNICAL SPECIFICATIONS



<b>Intensidad máxima:</b>	<b>6A/125VCA - 3A/250VCA</b>
<b>Rating:</b>	<b>6A/125VCA - 3A/250VCA</b>
<b>Resistencia de contacto:</b>	<b>20 mΩ máx.</b>
<b>Contac resistance:</b>	<b>20 mΩ max.</b>
<b>Resistencia de aislamiento:</b>	<b>1000 MΩ a 500 VCC</b>
<b>Insulation resistance:</b>	<b>1000 MΩ to 500 VCC</b>
<b>Rigidez dieléctrica:</b>	<b>1500 VCA 1 minuto</b>
<b>Dielectric strength:</b>	<b>1500 VCA 1 minute</b>
<b>Temperatura de trabajo:</b>	<b>-25°C a +85°C</b>
<b>Work temperature:</b>	<b>-25°C to +85°C</b>
<b>Maniobras:</b>	<b>10.000</b>
<b>Electrical life-cycles:</b>	<b>10.000</b>
<b>Cuerpo:</b>	<b>Baquelita</b>
<b>Body:</b>	<b>Bakelite</b>
<b>Terminales:</b>	<b>Sellados con epoxy:</b>
<b>Terminals:</b>	<b>Epoxy sealed</b>

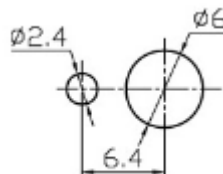
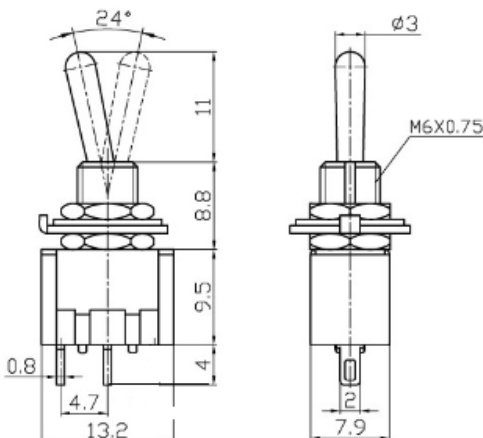

**ELECTRO DH s.a.**

Fortuna 29  
08902 Hospitalet de LL (BCN)

