



## DATOS TÉCNICOS DATASHEET



**MARCA :** ELECTRO DH

**BRAND:** ELECTRO DH

**CÓDIGO:** 11.411.IL/NR/6

**CODE:** 11.411.IL/NR/6

**DESCRIPCIÓN:** Interruptor térmico bimetálico luminoso rearmable.

**DESCRIPTION:** Bimetallic thermal switch resettable.

### ESPECIFICACIONES TÉCNICAS

#### TECHNICAL SPECIFICATIONS

<b>Voltaje:</b>	250 VAC
<b>Voltage:</b>	250 VAC
<b>Intensidad:</b>	6 A.
<b>Intensity:</b>	6 A.
<b>Cubierta:</b>	Nylon (negro)
<b>Cover:</b>	Nylon (black)
<b>Balancín:</b>	ABS (rojo)
<b>Rocker:</b>	ABS (red)
<b>Terminales:</b>	Aleación de cobre niquelado
<b>Terminals:</b>	Nickel-plated copper alloy
<b>Contacto:</b>	Plata/Cobre
<b>Contacto:</b>	Silver/copper
<b>Resistencia lámpara neón:</b>	150k $\Omega$
<b>Neon lamp resistance:</b>	150K $\Omega$
<b>Voltaje encendido lámpara neón:</b>	$\leq 95$ VAC
<b>Ignition voltage neon lamp:</b>	$\leq 95$ VAC

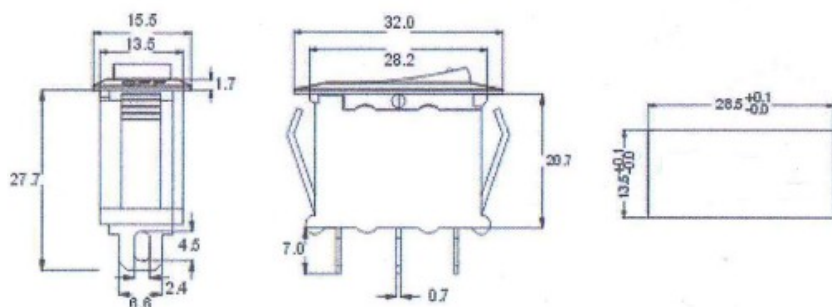

Esquema de Montaje

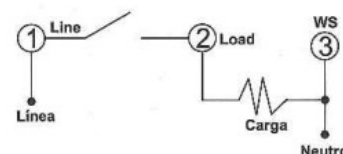

**ELECTRO DH s.a.**

Fortuna 29  
08902 Hospitalet de LL (BCN)